

MYPro series MYTower™ 5 storage system

Specifications
November 2021



Specifications MYPro series **MYTower™**

CAPABILITY	
STORAGE SYSTEM FOR SMD REELS	
Reel sizes	4-32mm (4"/100mm reels)
	4-32mm (7"/180mm reels)
	4-56mm (13"/300mm reels)
	4-56mm (15"/380 mm reels)
Freely configurable and expandable	
Access time	5 reels/minute

CAPACITY		
MAXIMUM REELS		
Tower model	Reel size	Number of reels
MYTower 5	4mm/4-7"	812
MYTower 6	4mm/ 4-7" or 8mm/ 4-7"	980
MYTower 6+	4mm/ 4-7" or 8mm/ 4-7"	980
MYTower 7+	4mm/ 4-7" or 8mm/ 4-7"	1,148
MYTower 5x	4mm/4-7"	2,052
MYTower 6x	4mm/4-7"	2,468

CASSETTES			
CASSETTES AVAILABLE			
Reel width	4-7" Reel diameter	13" Reel diameter	15" Reel diameter
4mm	• ⁽¹⁾	• ⁽¹⁾	• ⁽¹⁾
8mm	•	•	•
12mm	•	•	•
16mm	•	•	•
24mm	•	•	•
32mm	•	•	•
44mm		•	•
56mm		•	•

⁽¹⁾ Only available in MYTower 5x and 6x

SOFTWARE		
SOFTWARE FUNCTIONS	Standard mode	MYCenter oode
Component management	•	• ⁽¹⁾
Stock monitoring	•	• ⁽¹⁾
External communication protocol	•	•
User access system	•	•
Traceability	•	•
Job preparation	•	• ⁽¹⁾
Barcoding	•	• ⁽¹⁾
Data import/export function	•	• ⁽¹⁾
Inventory function	•	• ⁽¹⁾
Component allocation	•	

⁽¹⁾ Handled by MYCenter software

ACCESSORY	
DRY AIR UNIT FREY FND 3.0 F-DP	
Flow rate, max	(in) 24m ³ /h, (out) 20m ³ /h
Flow rate, type	3m ³ /h
Air supply	Class 4 (ISO 8573-1) or better
Operating pressure	5-10bar
Power supply	115/230V, 50/60hz, 18W
Dimension (WxDxH)	330mmx270mmx840mm (13.0" x10.6" x 33.1")

DRY AIR UNIT DST DC-20/30 T10/T16	
Weight	32kg
Power supply	115/230V, 50/60hz
Dimension (WxDxH)	435mmx243mmx663mm

MYTower 5

The MYTower 5 is Mycronic's most compact component storage system. Perfectly suited for customers with limited floor space and height restrictions in their factory. The MYTower 5 has a maximum capacity of 812 reels, and is easily configurable to store 4-15" reels.



CONFIGURATION		
STANDARD CONFIGURATION		
Reel size	Number of reels	Total
8mm/4-7"	56	354
8mm/13"	56	
8mm/15"	0	
12mm/4-7"	48	
12mm/13"	36	
12mm/15"	24	
16mm/4-7"	20	
16mm/13"	30	
16mm/15"	10	
24mm/4-7"	0	
24mm/13"	16	
24mm/15"	16	
32mm/4-7"	0	
32mm/13"	14	
32mm/15"	14	
44mm/13"	5	
44mm/15"	5	
56mm/13"	0	
56mm/15"	4	

MISCELLANEOUS	
INSTALLATION REQUIREMENTS	
Weight	270kg/600lbs
Power requirements	Single phase AC 300 VA
Voltage	115/230V, 50/60hz
Ambient temperature	18-35°C (65-95°F), < 95% RH non condensing

DIMENSIONS

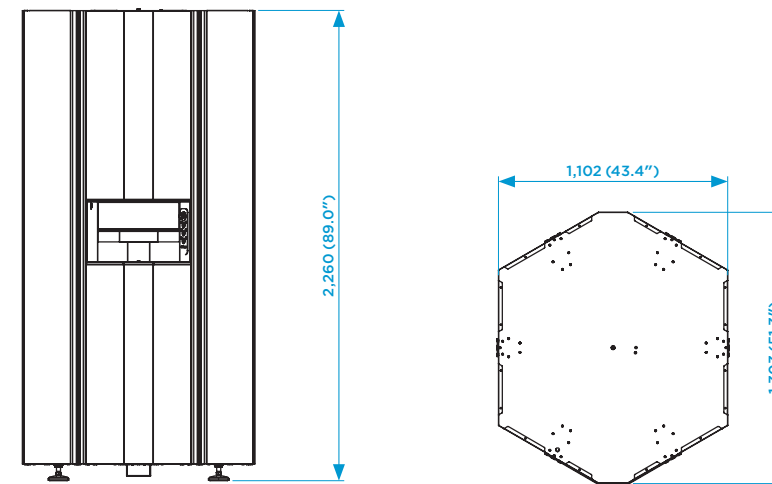

SWEDEN

Mycronic AB
PO Box 3141
Nytorpsvägen 9
SE-183 03 Täby
Sweden

Tel: +46 8 638 52 00

NETHERLANDS

Mycronic B.V.
High Tech Campus 10
5656 AE
Eindhoven
Netherlands

Tel: +31 402 62 06 67

FRANCE

Mycronic S.A.S.
1 rue de Traversière
CS 80045
94513 Rungis Cedex 1
France

Tel: +33 1 41 80 15 80

SOUTH KOREA

Mycronic Co. Ltd.
3rd Floor, Jung-San Bldg.
163 LS-ro Gunpo-Si
Gyonggi-Do, 15808
South Korea

Tel: +82 31 387 5111

SINGAPORE

Mycronic Pte., Ltd.
9 Tagore Lane,
#02-08/09
9@Tagore
Singapore 787472

Tel: +65 6281 7997

GERMANY

Mycronic GmbH
Biberger Straße 93
D-82008 Unterhaching
bei München
Germany

Tel: +49 89 4524248-0

UK

Mycronic Ltd.
Unit 2, Concept Park
Innovation Close
Poole, Dorset, BH12 4QT
UK

Tel: +44 1202 723 585

CHINA

Mycronic Co., Ltd.
Unit 106, E Block
Lane 168, Da Duhe Road.
Putuo District, 200062
Shanghai P.R. China

Tel: +86 21 3252 3785/86

JAPAN

Mycronic Technologies KK
KDX Chofu Bldg.7th floor
1-18-1 Chofugaoka,
Chofu-shi
Tokyo 182-0021
Japan

Tel: +81 42 433 9400

USA

Mycronic Inc.
554 Clark Road
Tewksbury
MA 01C876-1731
USA

Tel: +1 978 495 9799